

Sure-Clamp Access

Round: Unlined

SPECIFICATIONS

- A. **General Description:** The removable ductwork section features a clamp connection for easy installation and removal. The gasket clamps ensures a secure and tight connection, reducing air leakage and improving overall system performance. When it's time for fire damper inspection the ductwork section can be easily removed and replace without the need for specialized tools, this designed is practical, efficient and takes 50% less time to make mandatory fire damper inspections.
- B. **Allowable Leakage:** 1/2 CFM per 100 square ft. of ductwork surface area.
- C. **Size:** 18" maximum diameter
- D. **Material:** Galvanized ASTM A527
- E. **Liner:** N/A
- F. **Flange Connection:** 90 degree continuous machine formed flange.
- G. **Seams:** (RL-3) Lap and spot weld on 2" interval
- H. **Access Section:** Length 12" / 22 gauge 4" through 12" diameter and 20 gauge 13" through 18" diameter.
- I. **Clamps:** 20 gauge electro plated steel and adjustable tee latch. Gasket profile forms to the inside of clamp and seals the outer edges of the ductwork flange.
- J. **Gasket:** Thermoplastic elastomer TPE-E Temp. resistance -140 to +176F
- K. **Seal Seams:** In accordance with SMACNA HVAC Duct Construction Standard - Metal and Flexible.
- L. **Installation:** The removable access section shall not be more than 4" away from the fire damper sleeve break away connection. Installing contractor to provide manufacturer with quantity and size for fabrication.
- M. **Manufacturer:** Langdon, Inc.
9865 Wayne Avenue
Cincinnati, Ohio 45215
Phone (513) 733-5955

SURE • CLAMP™ ACCESS (PATENTED)

SURE CLAMP™ UNLINED
DETAIL

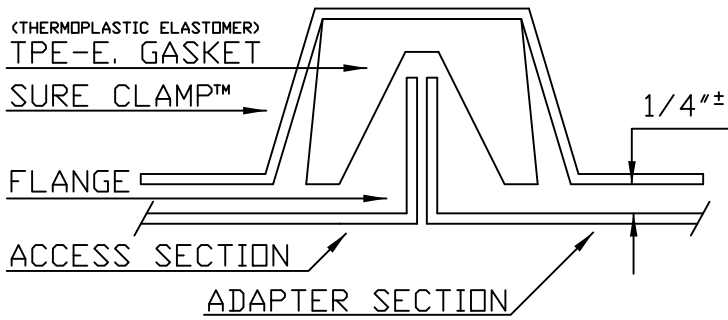
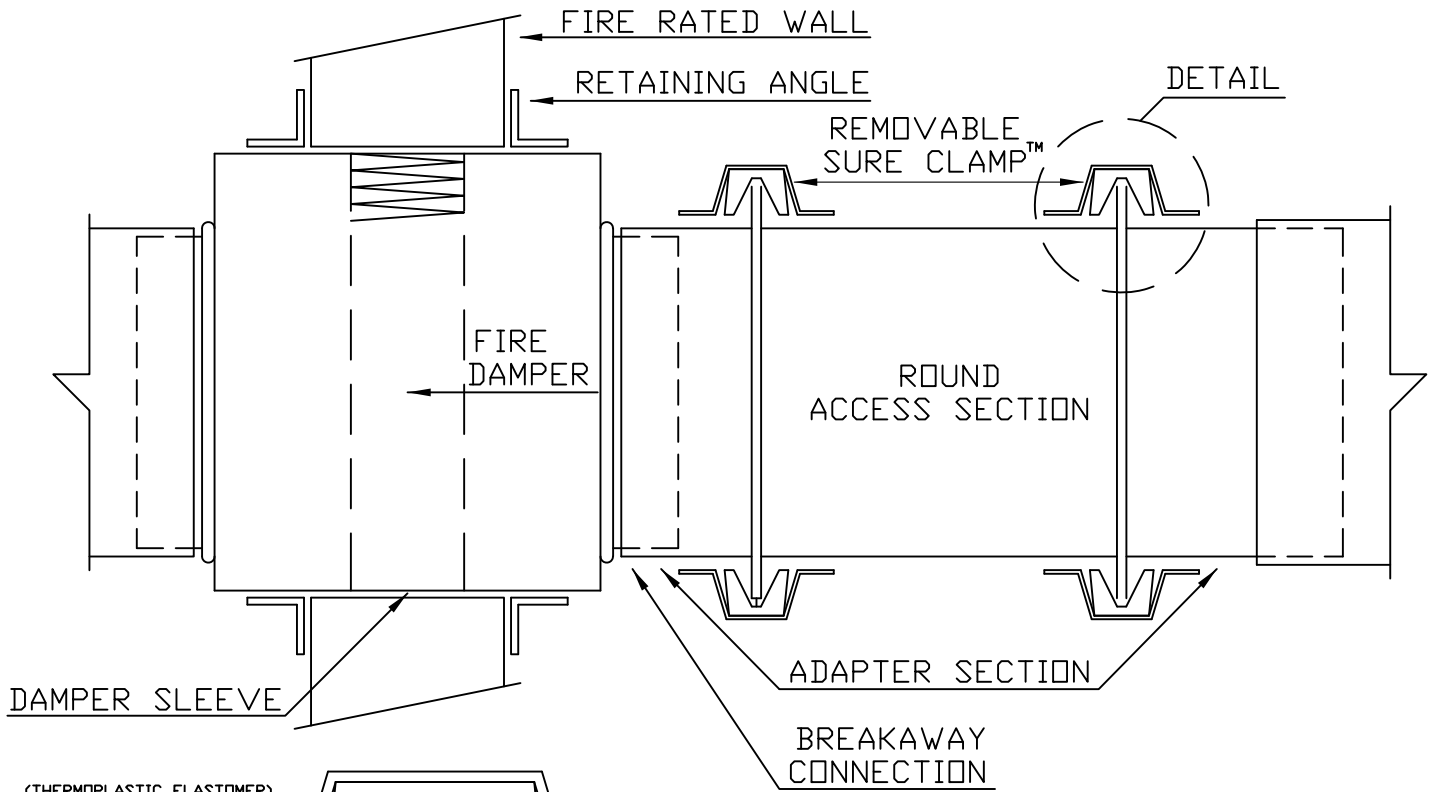

STANDARD FLANGE

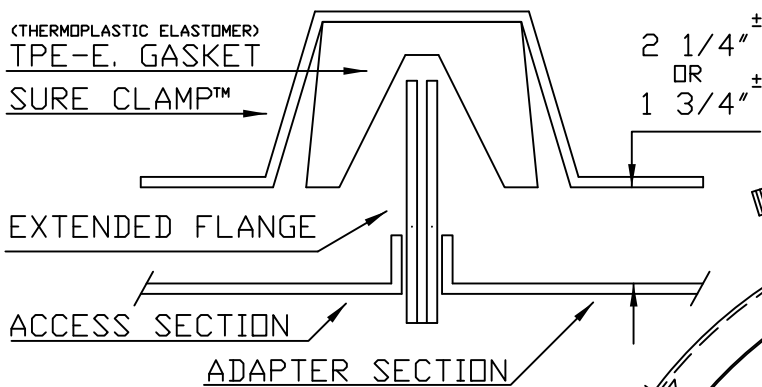

EXTENDED FLANGE

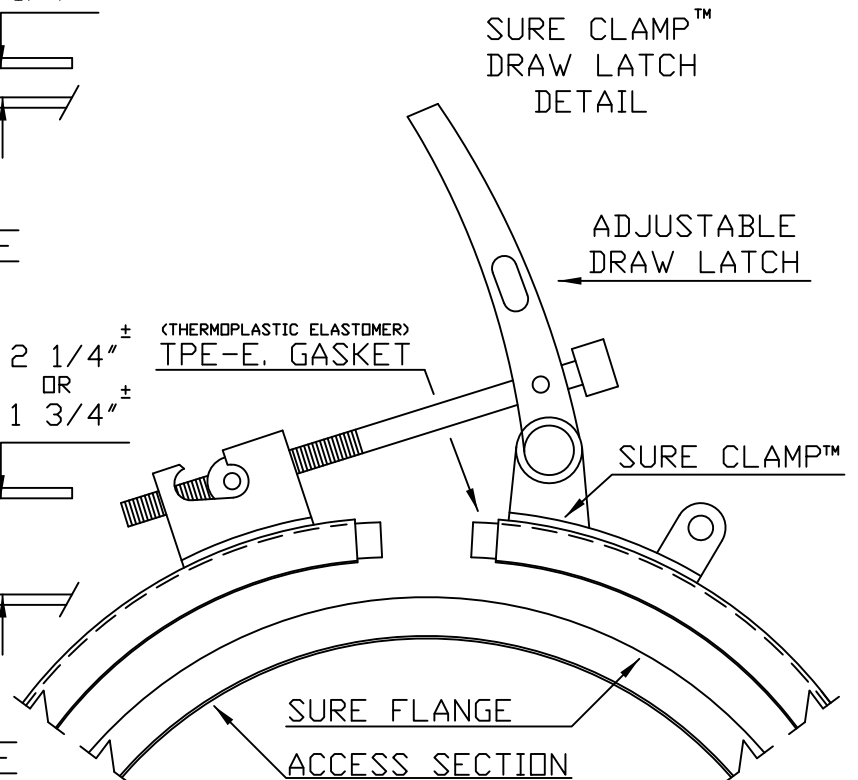

www.langdonsheetmetal.com

Cincinnati, Ohio, 45215
The above mentioned product, is protected by patents and trade marks
All Rights Reserved updated 4/12/2023

ORDER FORM

SURE • CLAMP™ ACCESS

(PATENTED)

SURE CLAMP UNLINED
DETAIL

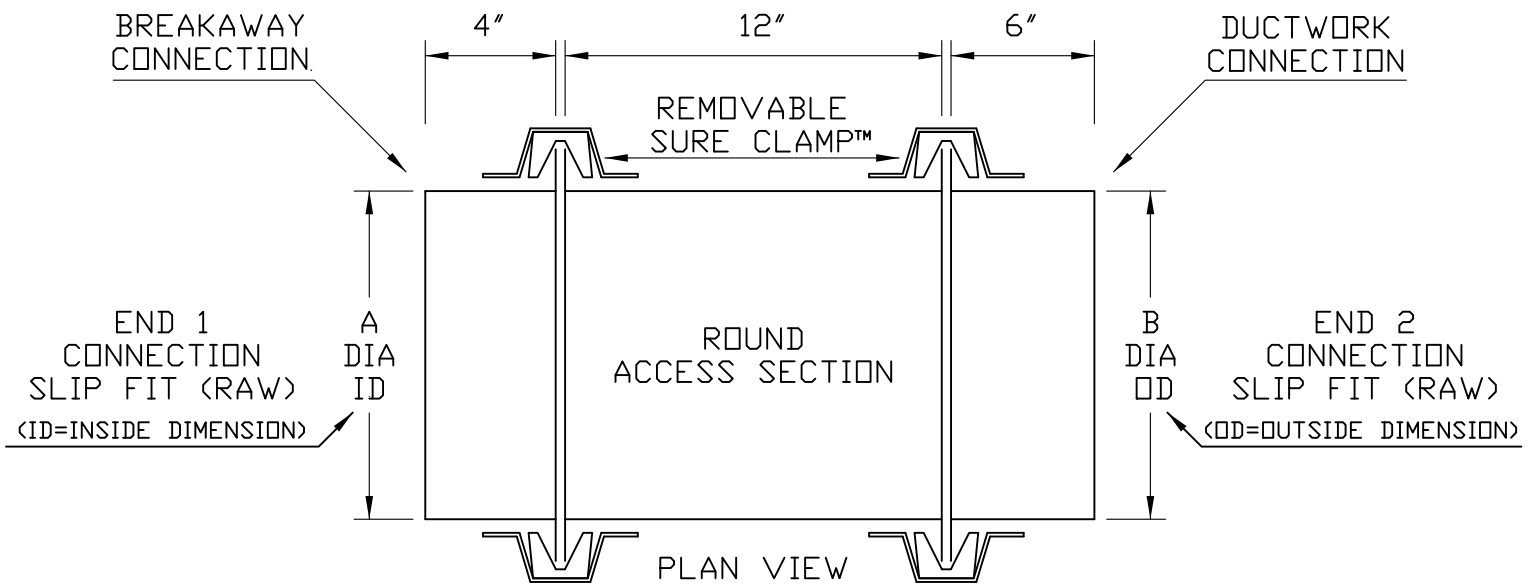

MATERIAL : 4"Ø/12"Ø 22 GAUGE GALVANIZED
13"Ø/18"Ø 20 GAUGE GALVANIZED

FABRICATE IN ACCORDANCE WITH
LANGDON'S DUCT CONSTRUCTION STANDARDS

MAXIMUM ACCESS SIZE 18" DIAMETER

TAG	QTY.	END 1 (A)	END 2 (B)
EXAMPLE	1	12"Ø ID	11.92"Ø OD
_____	_____	_____	_____
_____	_____	_____	_____
_____	_____	_____	_____
_____	_____	_____	_____
_____	_____	_____	_____
_____	_____	_____	_____
_____	_____	_____	_____
_____	_____	_____	_____

www.langdonsheetmetal.com